

REV	DESCRIPTION	INT:	REV. DATE	APPROVED
1	ECO# C01556	MJS	10/9/06	CG
2	ECO# C01973	MJS	10/11/2006	CG
3	ECO# C02415	DR		

**TITLE BOX PAGE ONLY.
DO NOT MAKE FILM • DO NOT PRINT**

MATERIAL: White 16lb (60g/m sq), uncoated, prefer recycled stock

Ink: Black

**Print Two Sides, 2 sheets 8.5" (Wide) x 11" (High),
stapled upper left corner**

OR

**Print Two Sides, 1 sheet 11" x 17"
folded to 8.5" x 11"**

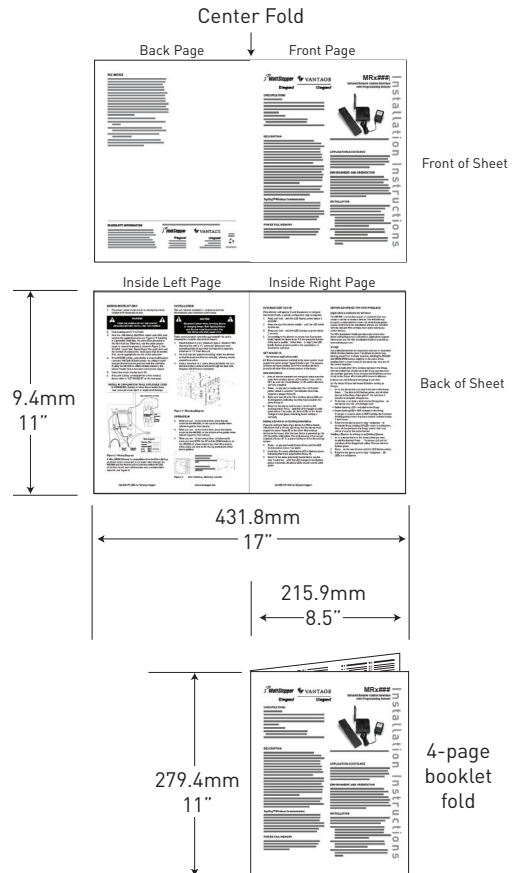

.#:
2

IF YOU HAVE ANY QUESTIONS REGARDING SPECIFICATIONS OR REQUIRE ADDITIONAL FILE FORMATTING, PLEASE CONTACT Mary Jo Sowinski.

Phone: 408-486-7511

Email: maryjo.sowinski@wattstopper.com

All information in this drawing is the property of Watt Stopper/Legrand and cannot be copied or used without the written approval of Watt Stopper/Legrand.

DRAWN BY	REVEL	 <p style="text-align: center;">SANTA CLARA, CALIFORNIA</p> <p style="text-align: center;">Title: MR2000 Installation Instructions</p>		
PLM				
MARCOM				
ENGINEERING				
QA				
TITLE BOX PG	SCALE 1:1	Drawing #: 06145	Orig. Drawing Date: 06 OCT 06 Revision Date: 01 OCT 07	REV. #: 3

SPECIFICATIONS

Voltages..... 120VAC/277VAC, 60Hz
 Output (Load) Powered via Input (Line) to Neutral
 Maximum Load Rating.....2000W@120VAC, 4432W@277VAC
 Minimum Load Required 100W@120VAC, 200W@277VAC
 Load Type Compatibility.....

Note: Burn-in lamps according to manufacturer’s instructions before dimming with the MR2000.

The following are limited to 2000W@120VAC max:

- Incandescent & quartz halogen
- Electronic low voltage dimming rated transformers
- Neon/cold cathode dimming rated ballasts

The following are limited to 2000W@120VAC or 4432W@277VAC max:

- Magnetic low voltage transformer
- Dimming rated 2-wire fluorescent (Advance MarkX or equivalent)
- Compact fluorescent dimming rated ballasts

Required Branch Circuit Overcurrent Protection
 Ratings: 120VAC/277VAC, 20A, 60 Hz

Environment
 Operating Temperature 32°-104°F [0°-40°C]
 Operating Humidity Less than 95%RH, non-condensing

DESCRIPTION

The Miro MR2000 is a high capacity universal dimmer designed for remote mounting in a 4” square box with a 1½” extender. The dimmer is suitable for surface, semi-recess or plenum mounting. Remote user control is available by either binding the MR2000 to a wireless Miro control device such as a wireless multilocation controller (see Figure 1) or by wiring the MR2000 to a Miro multilocation controller through a traveler wire (see Figure 2).

The MR2000 is wired directly to the load. It is a forward phase control dimmer with a normally open air-gap relay at the load output. It provides 120/277VAC, phase to neutral input to the load.

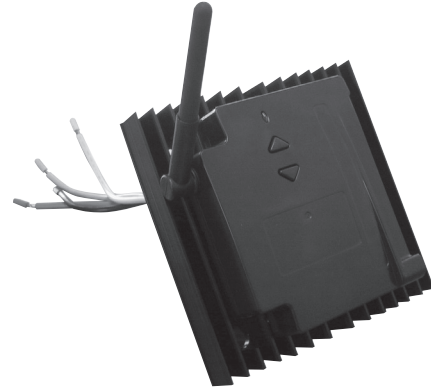
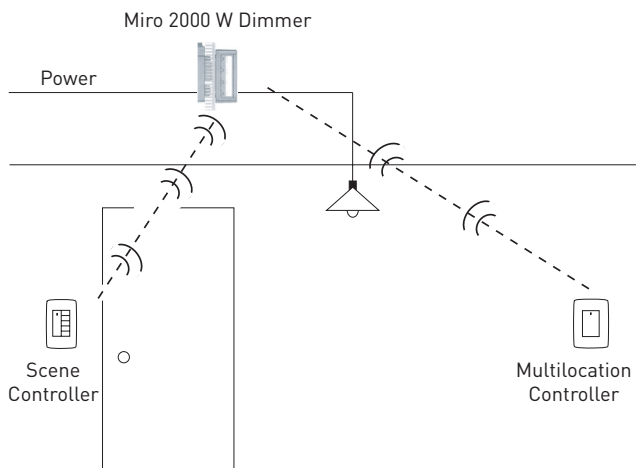

Top Dog™ Wireless Communication

Wireless devices use radio signals to communicate with each other to control lighting and other types of electric loads in selected areas. These wireless devices use the 900MHz band for high-speed control communication. Using “frequency-agile” Top Dog™ technology, these wireless devices avoid interference with other 900MHz devices, such as cordless phones and baby monitors.

Load Types

Use the Miro Universal Dimmer for these load types:

- Incandescent & quartz halogen lamps.
- Dimmable, 2-wire fluorescent and compact fluorescent, electronic low voltage, magnetic low voltage, neon or cold cathode.

Do not mix different load types on the same dimmer. Do not use with fluorescent lamps other than those listed. See SPECIFICATIONS.



CAUTION

Do not install to control a receptacle, or a motor-operated appliance.



ENVIRONMENT AND ORIENTATION

This product is designed for indoor use only where the ambient temperature in the unit’s vicinity does not exceed 104°F (40°C). Allow space for ventilating 100 BTU/Hr.

Unit must be mounted in a 2½” deep 4” square steel electrical box plus 1½” extension such that the heatsink is spaced 1½” away from the wall in which the 4” square box is mounted. Unit must be oriented such that the heatsink fins run lengthwise vertically to permit natural upward convection whether wall or plenum mounted. Allow a minimum of 6” space above and below the unit and do not block vertical airflow though the heatsink.

WIRING INSTRUCTIONS

1. Disconnect power to the circuit by turning the circuit breaker OFF before installation.

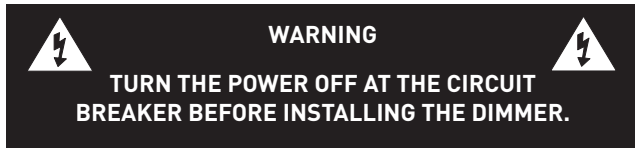

2. Strip existing wire 1/2" (12.7mm).
3. Wire the LINE (black), NEUTRAL (white) and LOAD lead wires to the supply/load wires per Figure 2. If installing in a grounded metal box, the unit will be grounded to the electrical box. Otherwise, use the green ground screw to connect to ground as shown in Figure 2. Use #12AWG copper wire. Depending on the application and the number of connections, more space may be needed. If so, use an appropriate size box or box extension.
4. If the MR2000 will be controlled by a wired multilocation controller (MCD68/DCD68) connect the yellow traveler wire per the instructions provided with the controller. If using the MR2000 in a Miro wireless network, the yellow traveler wire is not used and must be capped.
5. Switch the circuit breaker back ON.
6. If the unit is to be controlled from a Miro wireless device, refer to "SET HOUSE ID" on the next page.

INSTALL IN COMPLIANCE WITH ALL APPLICABLE CODES & STANDARDS. Failure to follow these instructions may cause personal injury or equipment damage.

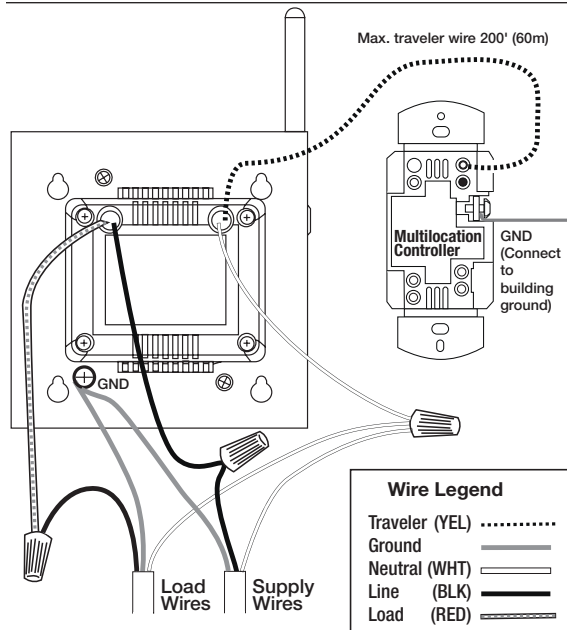
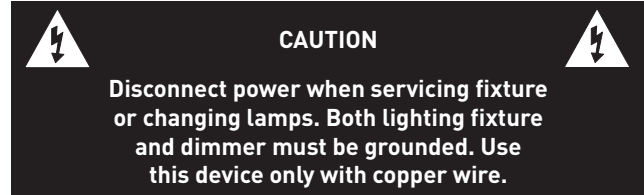

Figure 2 - Wiring Diagram

A Miro 2000W Dimmer is compatible with wired Miro devices, as shown above connected by a traveler wire between the MR2000 and the Multilocation Controller (either MCD68 or DCD68). It will also communicate with a wireless Miro network (see Figure 1).

INSTALLATION

The unit must be installed in compliance with the Environment and Orientation instructions.



Radio communication cannot be guaranteed if the unit is mounted in a metallic electrical enclosure.

1. Install dimmer in a 2 1/8" minimum deep 4" square (1900) electrical box with a 1 1/2" extension. Extension must extend beyond wall such that the heatsink is spaced a minimum of 1/2" from the wall.
2. For both wall and plenum mounting, orient the dimmer so that the heat sink fins run vertically, allowing natural upward convection.
3. Allow a minimum of 6" space above and below the unit and do not block vertical airflow through the heat sink. Requires 100 BTU/hour ventilation.

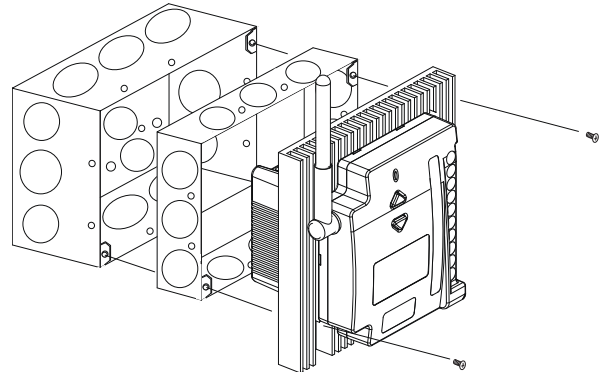

Figure 3 - Mounting Diagram

OPERATION

- When you see ↑ in the instructions, press the top button on the MR2000, or the top of the paddle when referencing other Miro devices.
- When you see ↓ in the instructions, press the bottom button on the MR2000, or the bottom of the paddle when referencing other Miro devices.
- When you see ⇅ in the instructions, simultaneously press and hold BOTH the UP and the DOWN buttons on the MR2000 (or, when referencing other Miro devices, firmly press and hold BOTH the top and bottom of the device paddle).

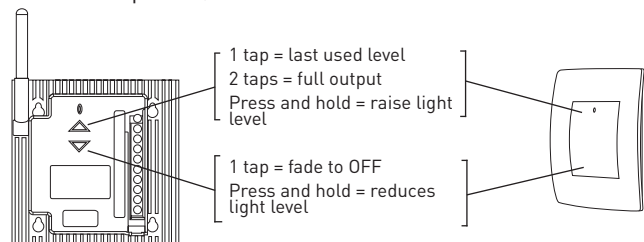

Figure 4: User Interface, dimming controls

FLUORESCENT SETUP

If the dimmer will operate 2-wire fluorescent or compact fluorescent loads, a special configuration step is required.

1. Press and hold ⬇ until the LED flashes yellow (about 2 seconds).
2. Press the top of the device paddle ⬆ until the LED briefly flashes red.
3. Press and hold ⬇ until the LED changes to green (about 2 seconds).
4. To reconfigure the dimmer to control non-fluorescent loads, repeat the above steps 1-3, but press the bottom of the device paddle ⬇ rather than ⬆ in step 2; the LED briefly flashes green to confirm the cancellation of fluorescent operation.

SET HOUSE ID

(for wireless applications only)

All Miro wireless devices installed in the same system must acquire the same unique House ID before use. This process is known as house binding. Each Miro wireless device is bound to all other Miro wireless devices in the house.

New Installation

1. With all devices installed and energized, make sure that every Miro wireless device LED is yellow. If any LED is OFF, be sure the circuit breaker is ON and the device is correctly installed.
2. Press ⬇ on any device paddle until the LED flashes yellow (about 2 seconds). This indicates that it has acquired a unique House ID.
3. Make sure that all other Miro wireless device LEDs are flashing green, indicating that they have acquired the same House ID.
4. Return to the device used in step 2, which is still flashing yellow. Press ⬇ until the LED changes to solid green (about 2 seconds). All device LEDs in the House change to solid green, indicating house binding is complete.

Adding a Device to an Existing Installation

If you are adding or replacing a device in a Miro wireless installation that is already operating, the new device must acquire the same House ID as the other Miro wireless devices in the house. After the new device is powered up, the LED should be solid yellow. This indicates that it has not yet acquired a House ID. To acquire the House ID for the existing system:

1. Press ⬇ on any **previously bound** device until the LED flashes yellow (about 2 seconds).
2. Verify that the newly added device LED is flashing green, indicating that it has acquired the House ID.
3. Return to the **same previously bound** device used in step 1 and press ⬇ until the LED changes to solid green (about 2 seconds). All device LEDs should now be solid green.

ADVANCED OPERATION FOR WIRELESS

Application Assistance for wireless

The MR2000 can function as part of a network that may contain a variety of wireless devices. The MR2000 may be easily incorporated into room and whole house preset scenes. Instructions for installation and use are included with the relevant Miro wireless room and whole house control devices.

The Miro Installation Guide provides more information about configuring scenes and presets. Application support information and the Miro Installation Guide is available at: www.wattstopper.com.

Groups

Use a MR2000 dimmer in conjunction with one or more Miro MRD8 Wireless Multilocation Controllers to control one lighting circuit from multiple locations. Binding the MR2000 and MRD8/DRD8 devices together in the same Group enables them to work in exactly the same way, from any of the control locations.

You can include other Miro wireless devices in the Group. Just remember that all devices in the Group operate when one member operates. If you increase the brightness on one circuit in the Group, all circuits will increase brightness.

A device can only belong to one group at any time.

Set the House ID (see Set House ID) before setting up Groups.

1. Go to any device that you want to include in the Group. Press ⬇. The device LED flashes yellow, and all other devices in the House flash green*. You now have 5 minutes to complete this process.
2. To include or exclude a device in the Group press ⬇ on the device until the LED changes color.
 - **Yellow** flashing LED = Included in the Group
 - **Green** flashing LED = NOT included in the GroupIf you get to a device and it is NOT flashing, the 5-minute binding process timer may have expired. Go back to step 1 and repeat.
3. Return to the device used in step 1 and press ⬇ to terminate Group binding. All LEDs revert to solid green. Now, all the devices in the Group control their load circuit in exactly the same manner.

*Adding a Dimmer to a Group in an Existing System

1. Go to a device that is in the Group where you want to add the dimmer. Press ⬇. The device LED and all members of the Group flash yellow. The new dimmer flashes green.
2. Press ⬇ on the new dimmer until it's LED flashes yellow.
3. Return to the device used in step 1 and press ⬇. All LEDs are solid green.

CLEANING & MAINTENANCE OPERATIONS

Clean only using a cloth dampened with water and a little mild detergent. Use of solvents or hydrocarbon-based cleaners may cause permanent damage.

Replacing Lamps

When a lamp must be replaced, disconnect power.

Power Fail Memory

After a power failure, all wireless devices automatically return to the state that they were in immediately prior to loss of power. All configuration and scene control information is preserved.

TROUBLESHOOTING FOR WIRELESS

During Set House ID, the LED is not flashing on some wireless Miro devices.

- If LED is solid green before initiating house ID binding: The device already has another house ID. Reset it to the factory default so that it can be bound to the desired house ID. Resetting to factory defaults is described in the "I need to start over" issue.
- If LED is solid yellow after initiating house ID binding: The device may be out of range of the initiating device. Add a MRR2 Miro Wireless Repeater to boost signal range.

I made a configuration mistake. I need to start over.

You can reset any Miro wireless device to factory default setting by pressing and holding ⚙ until the LED changes to solid yellow (approximately 10 seconds). During the process, the LED flashes yellow and when complete, it changes to solid yellow. The device can then be reconfigured, exactly like any new device (see the Set House ID section).

The Dimmer does not work and the status LED is flashing red.

- at 1Hz (5 times in 5 seconds): The dimmer has detected an unsuitable load or load below the minimum rated load for the applied voltage. To clear the fault condition, tap ⚡ and wait for the LED to turn green. Disconnect power, check the load, restore power and try again.

FCC NOTICE

FCC ID: Q4BMR2K

This device complies with part 15 of the FCC Rules. Operation is subject to the following two conditions: (1) This device may not cause harmful interference, and (2) this device must accept any interference received, including interference that may cause undesired operation.

Caution: Any changes or modifications to this device not explicitly approved by manufacturer could void your authority to operate this equipment.

WARRANTY INFORMATION

Manufacturer warranties its products to be free of defects in materials and workmanship for a period of five (5) years. There are no obligations or liabilities on the part of manufacturer for consequential damages arising out of, or in connection with, the use or performance of this product or other indirect damages with respect to loss of property, revenue or profit, or cost of removal, installation or reinstallation.

Legrand Customers contact:



301 Fulling Mill Road Suite G
Middletown, PA 17057
Phone: 800.321.2343
www.legrand.us/onq

Vantage Customers contact:



1061 South 800 East
Orem, UT 84097
Phone: 800.555.9891
www.vantagecontrols.com

Please
Recycle



06145r3 9/2007